

28mm 5-Sided Bay Pole Instructions

- Please read carefully before commencing

We strongly recommend that 2 people undertake the fixing of this pole

If fitting with a Return Kit, please open and read both sets of fixing instructions before installation.

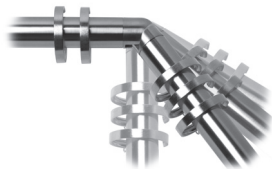
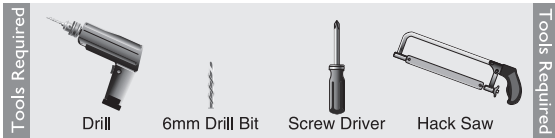

The unique corner joints in this Premier 5-Sided Bay Pole will fit into any 5-sided bay.

How The Completed Pole Should Look

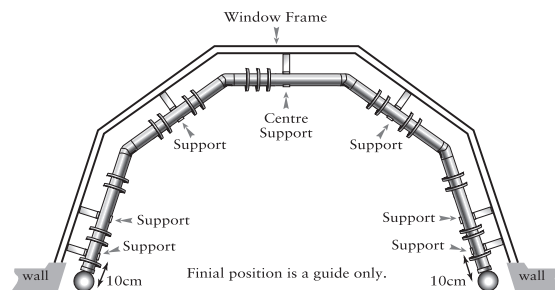

Support Positions

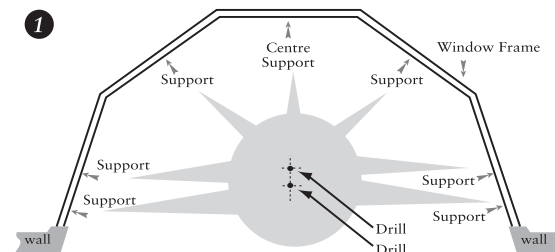

Mark and drill the positions using a 6mm drill bit, for the 7 supports as shown by arrows in the illustration that best matches your window size. Ensure the Centre Support is positioned in the middle of the window, and that the rest of the supports do not interfere with the corner joints. Insert the wall plugs supplied

Note: For extra strength, we recommend fixing the supports to a wooden batten.

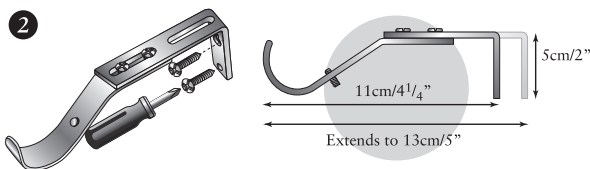

Fix the support brackets to the wall in the positions marked in step 1.

Adjusting Pole Length

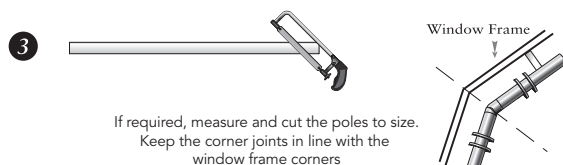

If required, measure and cut the poles to size. Keep the corner joints in line with the window frame corners

Assemble Pole Before Hanging

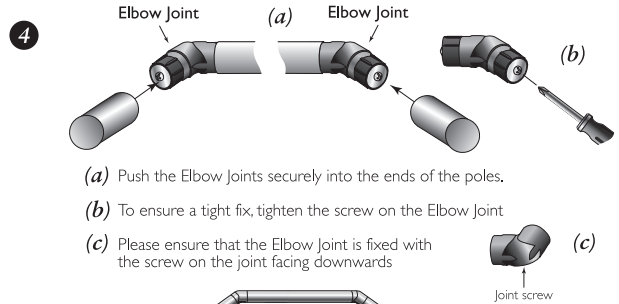

(a) Push the Elbow Joints securely into the ends of the poles.

(b) To ensure a tight fix, tighten the screw on the Elbow Joint

(c) Please ensure that the Elbow Joint is fixed with the screw on the joint facing downwards

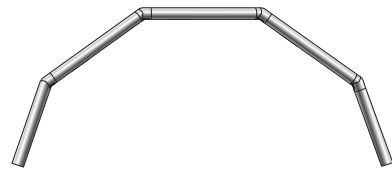

Hanging The Pole

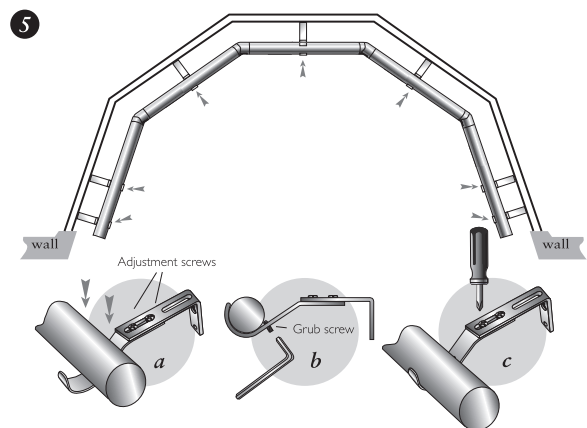

- Place the complete pole onto the supports. To help align the pole there are some adjustment screws on top of the supports.
- To hold the pole in position, tighten the grub screw underneath with the allen key supplied.
- Finally tighten the adjustment screws on top of the supports.

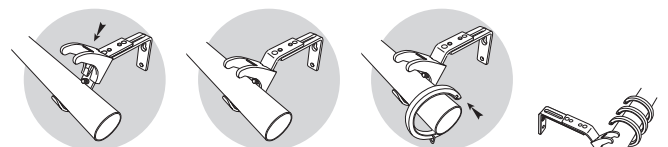
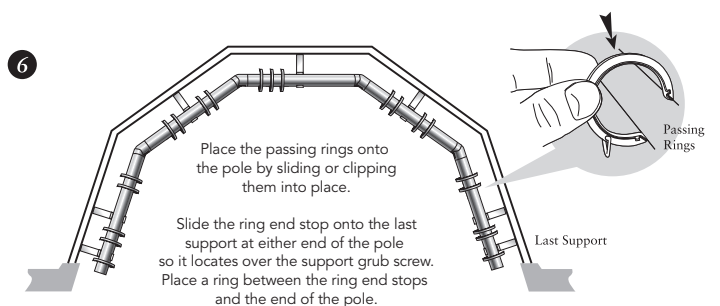

Secure finials onto pole - either push on for push-fit or secure using the allen key if it has a grub screw.

- To enhance the fit, we advise that you tighten the joint screws on the elbow of the corner joint refer to point 4c. We recommend that the rings are positioned at least 10cm apart to enhance the flow of the curtain.

Component parts may vary in style.