

TRACK TECHNICAL DETAILS and FITTING INSTRUCTIONS

SYSTEM 30 STRAIGHT

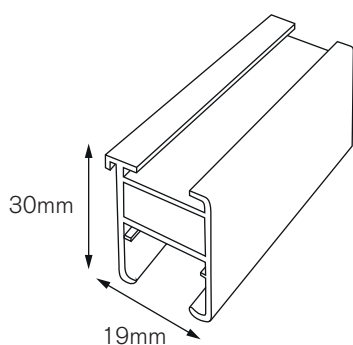

Top fix or face fix

BRACKET SPACING

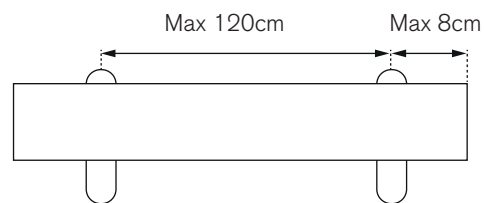

SYSTEM 30 BENDABLE

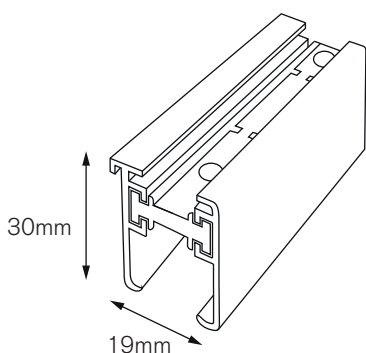

Top fix or face fix with brackets either side of every bend, max spacing 60cm

BRACKET SPACING

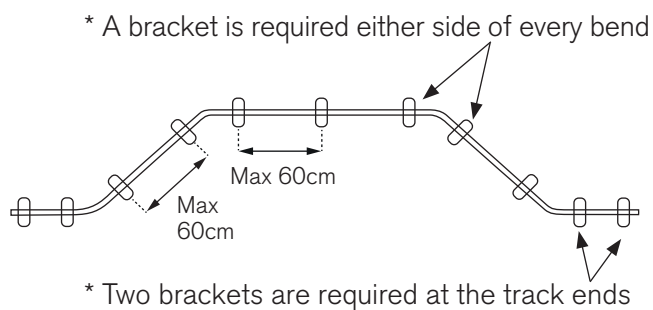

*The bay above shows a 600cm track with 11 brackets. Please check the bracket quantity supplied with your selected length.

Sales: 0845 465 0101

e-mail: info@polesandblinds.com

www.polesandblinds.com

SYSTEM 30 STRAIGHT

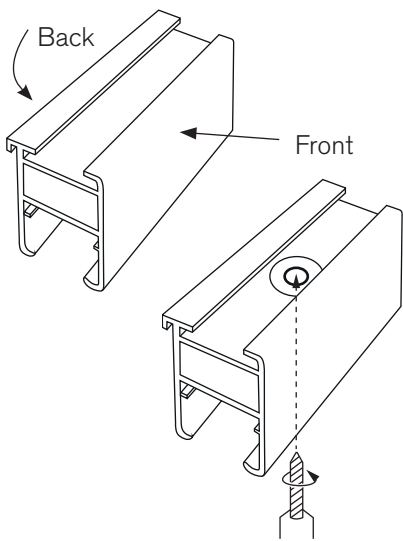

TOP FIXING

Fit track directly to ceiling or top board, using pre-drilled holes

For additional support simply drill more holes into the track using a 4mm drill bit (not supplied)

No brackets required

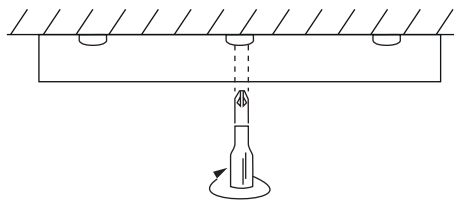

FACE FIX BRACKETS FOR SYSTEM 30

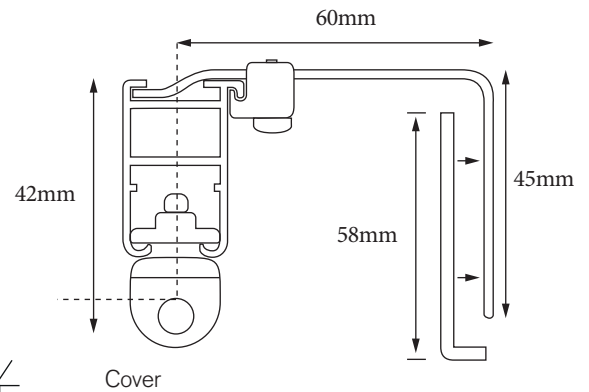

SYSTEM 30 BENDABLE

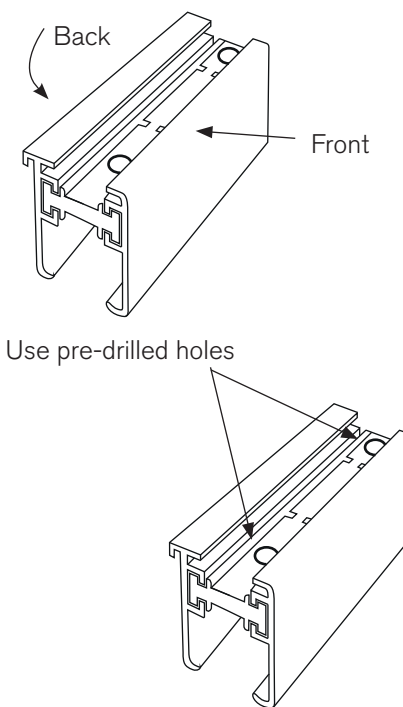

TOP FIXING

Fit track directly to ceiling or top board, using pre-drilled holes

No brackets required

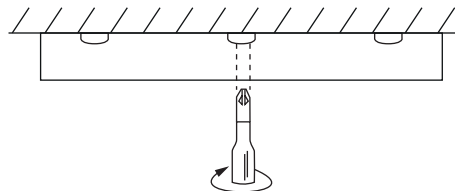

FACE FIX BRACKETS FOR SYSTEM 30

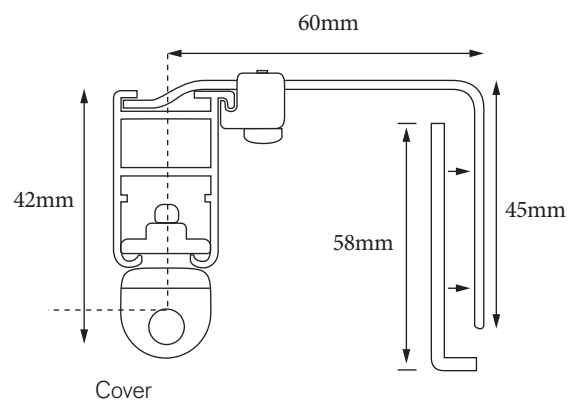

IMPORTANT

When top fixing bendable track, DO NOT over tighten screws as this can deform the track and cause the gliders to jam

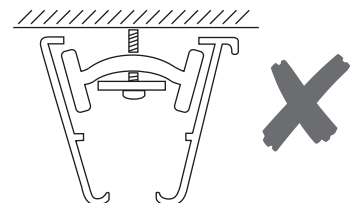

SYSTEM 30 STRAIGHT JOINER

Ensure magnet is at the front of the track so that the cover plate will locate correctly

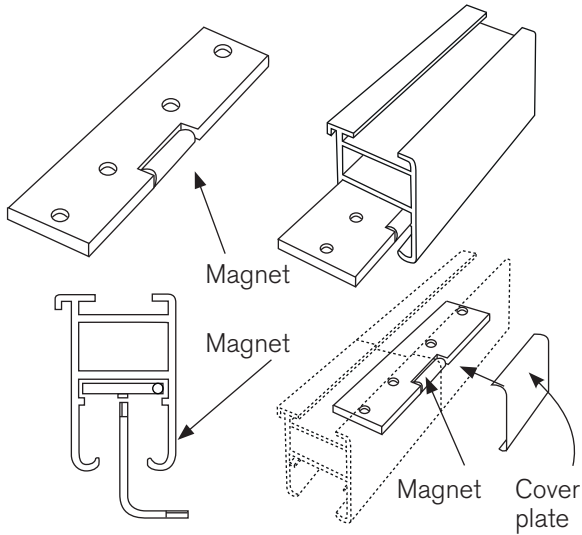

SYSTEM 30 BENDABLE JOINER

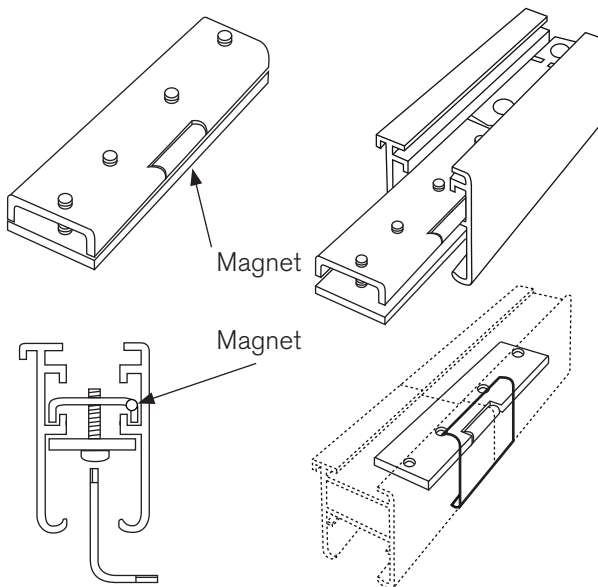

Remove part of the inner plastic section to create space to insert the joiner

Ensure magnet is at the front of the track so that the cover plate will locate correctly

FINIALS

The finials below are for System 30 straight and bendable only

Suitable for use with top fix

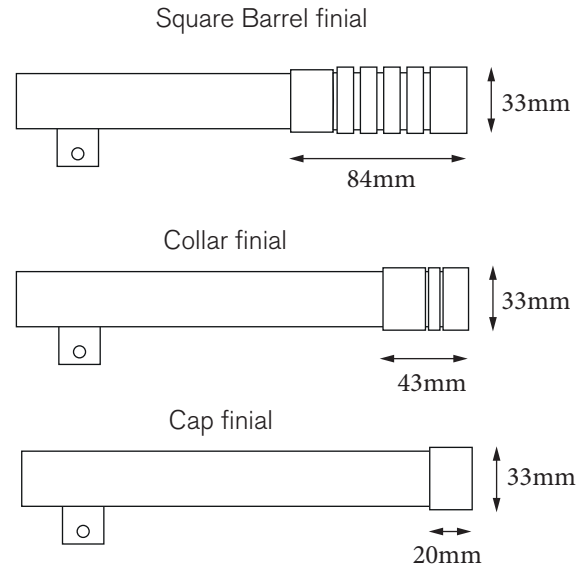

NOT Suitable for use with topfix

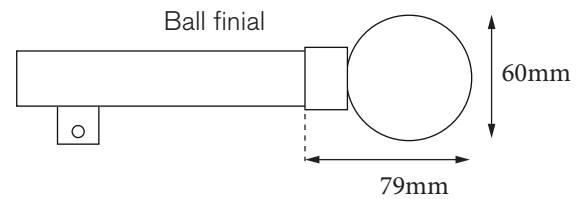

CURTAIN HEADINGS

We recommend curtain headings should be underslung for all three tracks to ensure the best operation of the curtains

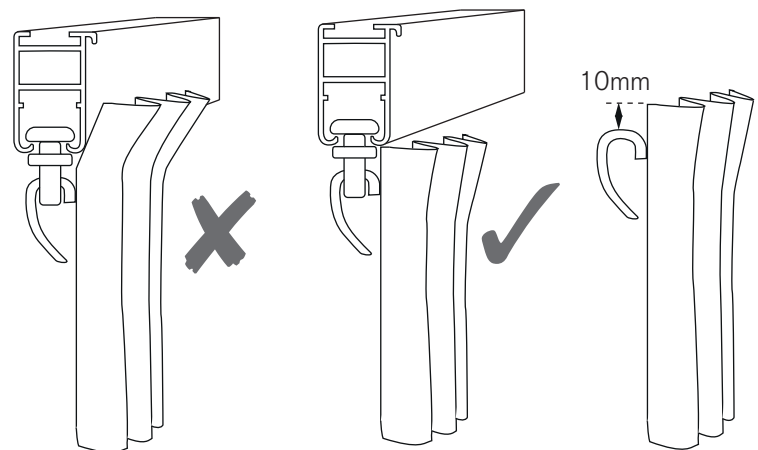

BENDING SYSTEM 30

Easy to bend on site at point of installation. No more measuring up and hoping.
No transporting awkward and delicate bent tracks

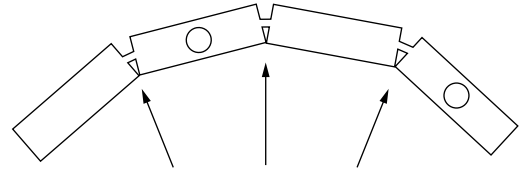
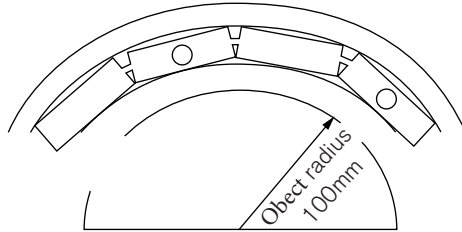
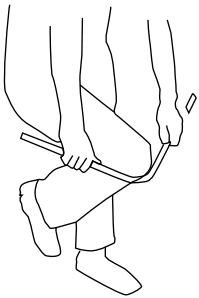

The track can be bent around a curved object with a radius of no less than 100mm. We recommend covering the track with a tea towel to prevent scratches.

Bend track until kerfs touch.
Do not bend any further

It's easy to achieve:

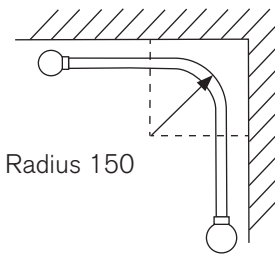

FORWARD BENDS

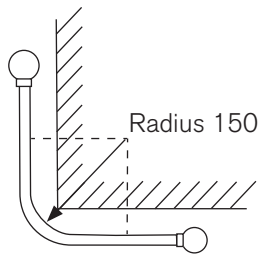

REVERSE BENDS

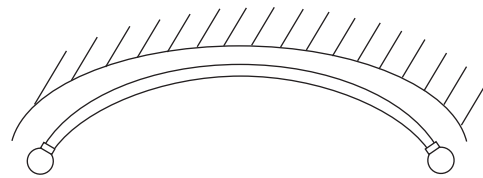

CONTINUOUS BENDS

Track lengths of 150cm - 300cm are supplied in 1 piece.
Track lengths of 360cm - 600cm are supplied in 2 pieces.
Track lengths of 720cm - 900cm are supplied in 3 pieces.

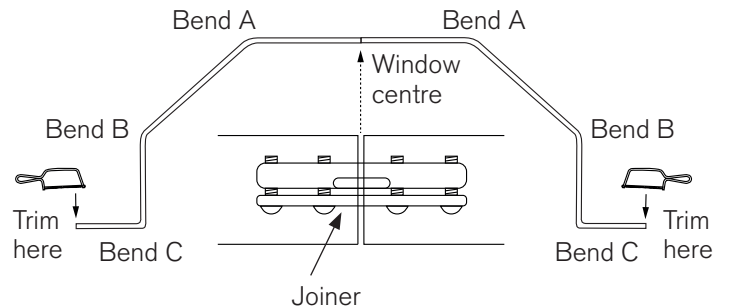
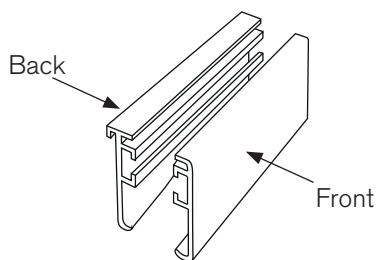

Diagram shows track joiner attaching two track lengths at the window centre

BENDING TO FIT A BAY

- 1 Identify front and back of track



- 2 Insert joiner, pushing the plastic filler down the track and tighten screws

- 3 Bend from the centre working outwards. Bend A, then B, then C, one side then A-C on the other side

- 4 Trim off excess track at the track ends

- 5 Bracket spacing - see front page

BENDING SYSTEM 30

Bend towards the straight end

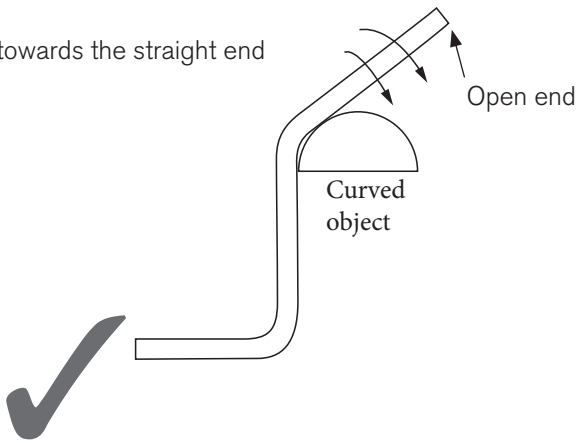

NOT LIKE THIS

DO NOT try to bend towards another bend

This method causes internal stress in the track which can cause the gliders to jam

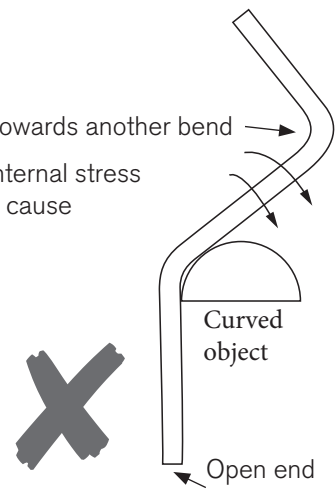

JOINING ALL TRACKS

- 1 Join together factory cut ends and trim off the excess at track ends only

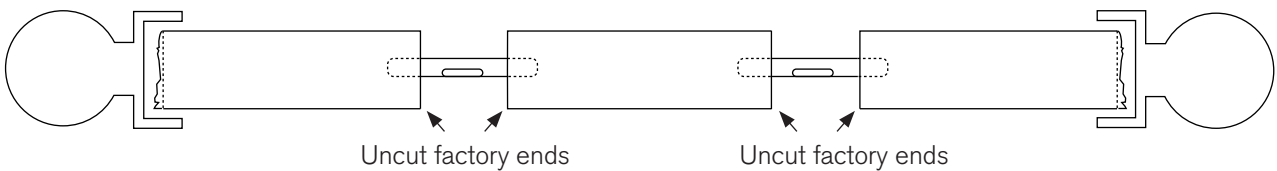
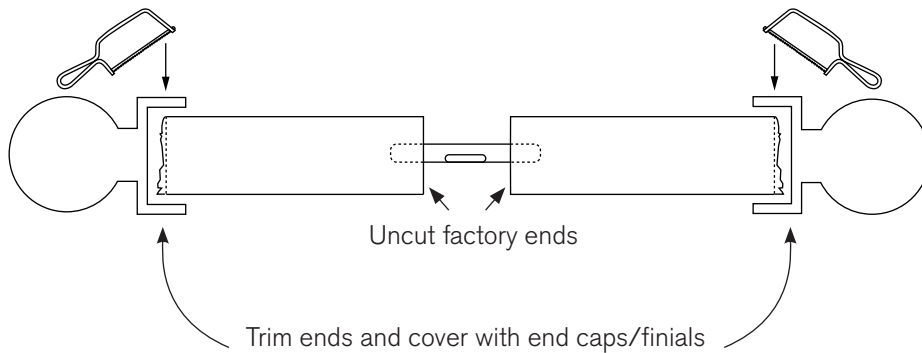

- 2 Place a support bracket as close as possible to the join

- 3 Ensure the joins are butted together tightly before tightening lock screws

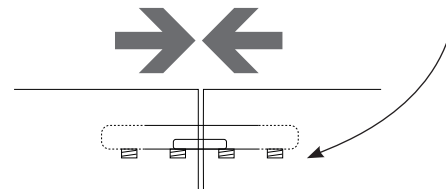

With careful installation gliders will smoothly pass over the track joins.
There is no limit to maximum track length

Sales: 0845 465 0101

e-mail: info@polesandblinds.com

www.polesandblinds.com